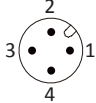

M30 ANALOG OUTPUT SERIES

ARTICLE PROPERTIES

SENSOR TYPE	Inductive sensor	CONNECTION TYPES (<i>see table</i>)
SIZE	M30x1.5	<ul style="list-style-type: none"> • cable PVC, 0.34 mm², 2 m** • M12 connector, A-coded
RATED OPERATING DISTANCE	<i>see table</i>	
NUMBER OF CONDUCTORS	4-wire (<i>see table</i>)	

** other cable lengths are available on request

MECHANICAL DATA

MOUNTING (mounting nuts included in delivery)	flush/non-flush (<i>see table</i>)
HOUSING	threaded cylindrical
LINEARITY ERROR	≤ 3 %
MATERIAL HOUSING	brass nickel-plated
MATERIAL SENSING SURFACE	PBT
TIGHTENING TORQUE	40 Nm
LOCKING	
STANDARD TEST	FE360
ATTENUATION COEFFICIENT	St37 = 1, V2A = 0.7, Al = 0.3

ELECTRICAL DATA

OPERATING VOLTAGE	DC: 15 ... 30 V DC
RATED OPERATING CURRENT	4-wire: ≤ 200 mA
SWITCHING FREQUENCY	<i>see table</i>
SWITCHING OUTPUT	<i>see table</i>
FUNCTION INDICATOR	yellow LED
HYSTERESIS	3 ... 15 %
TEMPERATURE DRIFT	±10 %
SHORT-CIRCUIT PROTECTION	yes
OVERLOAD RESISTANCE	yes
REVERSE POLARITY PROTECTION	yes

ENVIRONMENTAL CONDITIONS

PROTECTION CLASS	IP67	VIBRATION RESISTANCE (EN 60068-2-27)	55 Hz, 1 mm
AMBIENT TEMPERATURE	-25 ... 70 °C	SHOCK RESISTANCE (EN 60068-2-6)	30g/11 ms

STANDARDS AND DIRECTIVES

LOW-VOLTAGE SWITCHGEAR AND CONTROLGEAR	DIN EN IEC 60947-5-2:2021-04
---	------------------------------

APPROVALS



M30 ANALOG OUTPUT SERIES

DC 4-WIRE OUTPUT CABLE

Article number	Mounting	Rated operating distance Sn	Switching output (wiring diagram)	Switching frequency	Dimensions
Fi10-M30-LIU	flush	2 ... 10 mm	0 ... 10 VDC/0 ... 20 mA (WD15)	400 Hz	see Fig. 1
Ni15-M30-LIU	non-flush	3 ... 15 mm	0 ... 10 VDC/0 ... 20 mA (WD15)	200 Hz	see Fig. 2

DC 4-WIRE OUTPUT M12 CONNECTOR

Article number	Mounting	Rated operating distance Sn	Switching output (wiring diagram)	Switching frequency	Dimensions
Fi10-M30-LIU-Q12	flush	2 ... 10 mm	0 ... 10 VDC/0 ... 20 mA (WD15)	400 Hz	see Fig. 3
Ni15-M30-LIU-Q12	non-flush	3 ... 15 mm	0 ... 10 VDC/0 ... 20 mA (WD15)	200 Hz	see Fig. 4

DIMENSIONS

Fig. 1 Inductive sensor with cable (flush)

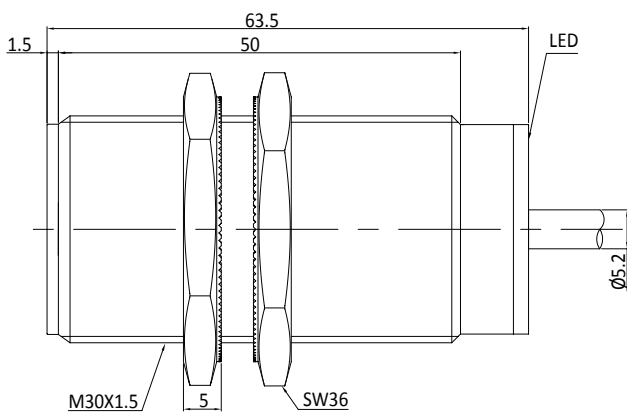

Fig. 2 Inductive sensor with cable (non-flush)

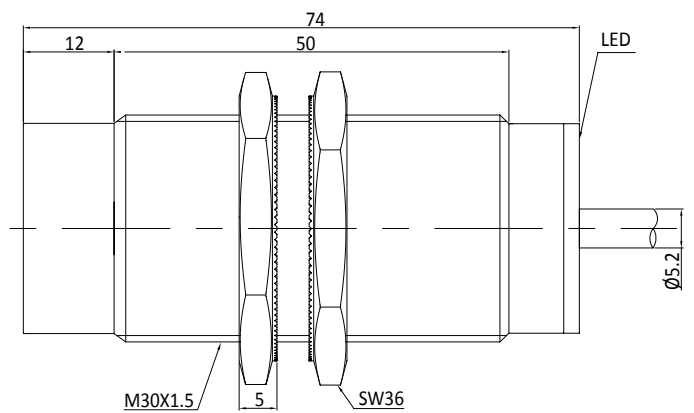

Fig. 3 Inductive sensor with M12 connector (flush)

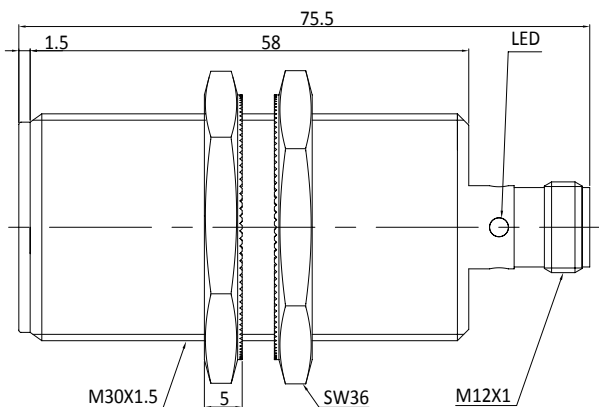
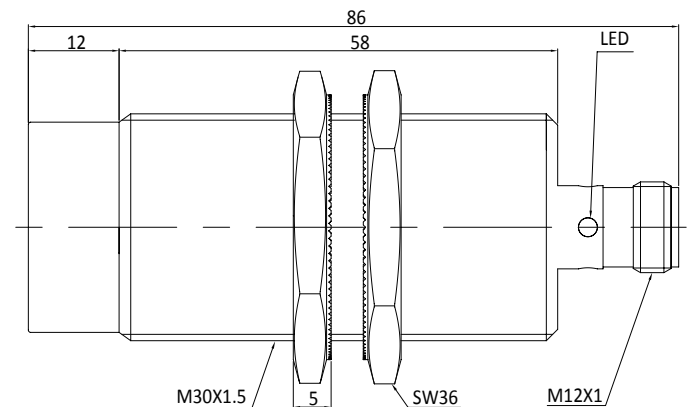

Fig. 4 Inductive sensor with M12 connector (non-flush)



M30 ANALOG OUTPUT SERIES

WIRING DIAGRAMS (Note: 1 / 2 / 3 / 4 connector and terminals pin number Bn / Bu / Wh / Bk cable color)

WD1 DC 2-wire NO

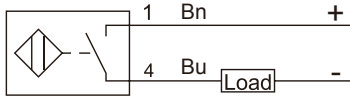

WD2 DC 2-wire NC

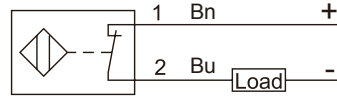

WD3 AC 2-wire NO

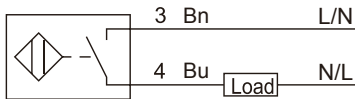

WD4 AC 2-wire NC

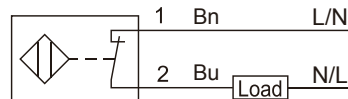

WD5 AC / DC 2-wire NO

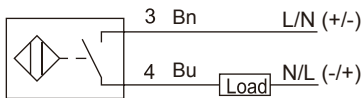

WD6 AC / DC 2-wire NC

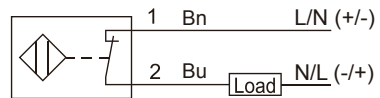

WD7 DC 3-wire PNP NO

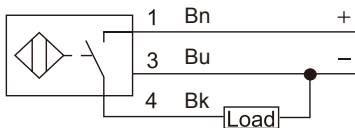

WD8 DC 3-wire NPN NO

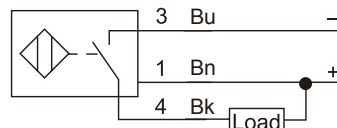

WD9 DC 3-wire PNP NC

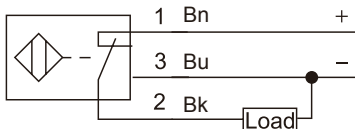

WD10 DC 3-wire NPN NC

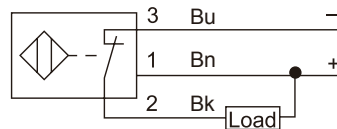

WD11 DC 4-wire PNP NO + NC

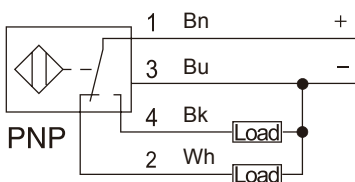

WD12 DC 4-wire NPN NO + NC

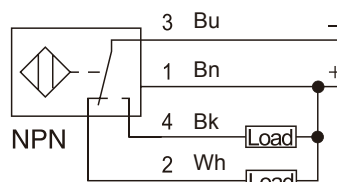

M30 ANALOG OUTPUT SERIES

WIRING DIAGRAMS (Note: 1 / 2 / 3 / 4 connector and terminals pin number Bn / Bu / Wh / Bk cable color)

WD13 AC/DC 4-wire NO+NC

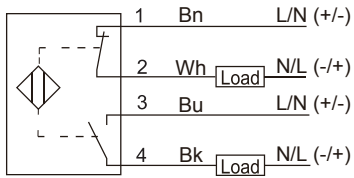

WD14 NAMUR 2-wire NC

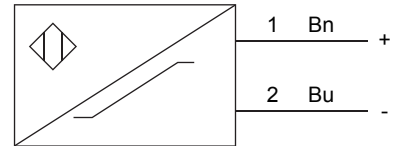

WD15 DC 4-wire 0-10V+0-20mA

